

# Bleed & Purge Valve

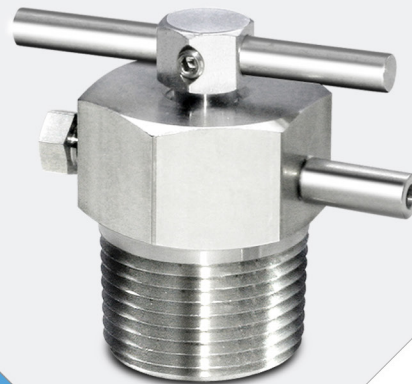

# Bleed Valves

## Applications

SUPERLOK bleed valves can be used on instrumentation devices such as multivalve manifolds or gauge valves to vent signal line pressure to atmosphere before removal of an instrument or to assist in calibration of control devices.

## Features

- Compact for convenient installation.
- Back stop screw prevents accidental remove of stem.
- Chrome-plated stem threads and tip improves valve life.
- Male NPT or ISO Thread end connection.

## Caution

When installing a SUPERLOK bleed valve, position the vent tube to direct system fluid away from operating personnel. Always open bleed valves slowly. These valves contain no packing, so some fluid will occur when the valves are opened. Operating personnel must protect themselves from exposure to system fluids.

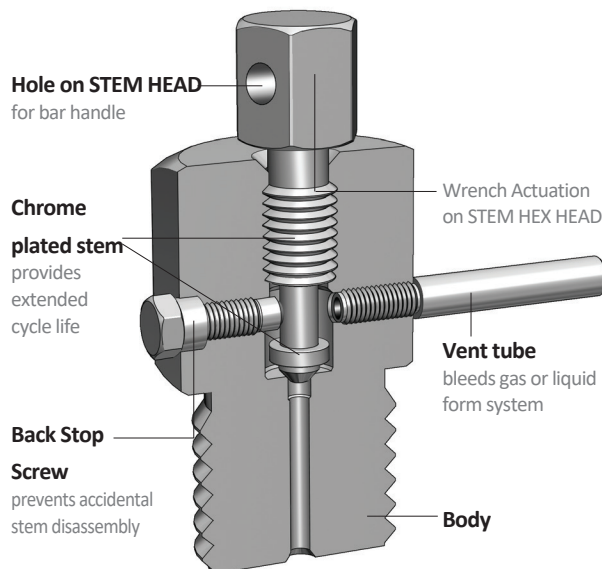

## Materials of Construction

Component	Valve Body Materials
Stem	316 SS / A276
Body	316 SS / A276
Back stop screw	316 SS / A276
Vent tube	316 SS / A269

## Pressure - temperature ratings

Temperature, °F(°C)	Working Pressure, psig (bar)
-65(-53) to 100(37)	10,000(689)
200(93)	9,290(640)
300(148)	8,390(578)
400(204)	7,705(530)
450(232)	7,435(512)
500(260)	7,165(493)
600(315)	6,770(466)
650(343)	6,660(458)
700(371)	6,840(446)
750(398)	6,335(436)
800(426)	6,230(429)
850(454)	6,085(419)

• Rating based on 316 stainless steel body material.

## Technical Data

Series	Orifice in.(mm)	Pressure-Temperature Rating	
		Temperature	Working Pressure
SBLV	0.125 (3.2)	-65 to 850°F (-54 to 454°C)	10,000psig (689bar) @100°F (38°C)

## Table of Dimension

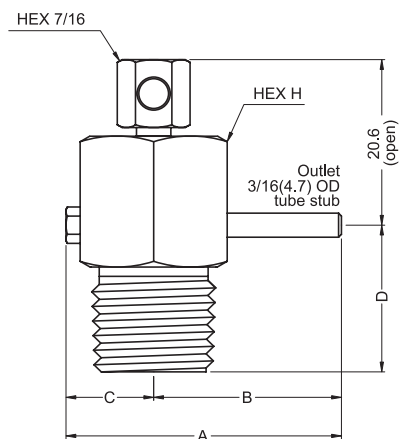

* Part No.	End Connection		Cv	Dimensions inch(mm)					
	Inlet	Outlet		A	B	C	D	H	
SBLV-M2N	1/8" Male NPT	O.D. 3/16" tube stub	0.25	1.34 (34.0)	0.92 (23.4)	0.41 (10.4)	0.75 (19.1)	0.625 (15.87)	
SBLV-M4N	1/4" Male NPT			1.47 (37.3)	1.03 (26.1)	0.44 (11.2)	0.88 (22.3)	0.875 (22.22)	
SBLV-M6N	3/8" Male NPT			1.87 (47.6)	1.15 (29.3)	0.72 (18.3)	1 (25.4)	1.125 (28.57)	
SBLV-M8N	1/2" Male NPT								
SBLV-M12N	3/4" Male NPT								

\* To order a valve with 316 stainless steel bar handle, suffix "-BH" to the part number. (Example: SBLV-M4N-BH)

## Testing

- Each valve is tested with nitrogen@1000psig(69bar)to max leak rate of 0.1 SCCM.
- Hydrostatic shell test is performed at 1.5times the working pressure as an option.

- Components can limit the pressure and temperature ranges of the valve. Please consult BMT (SUPERLOK) sales representative for your specific application.
- Dimensions and Drawings are for reference only and are subject to change without prior notice.
- Unless otherwise specified, all dimensions are in millimeters.
- Sizes, pressure classes, and end connections not listed are available upon request.
- Dimensions shown with SUPERLOK nuts finger-tight, where applicable.

# Purge Valves

## Applications

SUPERLOK purge valves are manual bleed, vent, or drain valves. One-quarter turn with a wrench from finger-tight obtains leaktight closure on first makeup. Snugging with a wrench ensures closure to the rated pressure with subsequent makeups.

## Features

- Compact for convenient installation.
- Vent hole is bled excessive liquid or gas from system lines.
- Cap is crimped to valve body to prevent accidental disassembly.
- Variety of end connections : SUPERLOK tube fittings, NPT and ISO threads.

## Caution

When installing a SUPERLOK purge valve, position the vent hole to direct system fluid away from operating personnel. The vent hole rotates with the cap. changing the direction of discharge as the cap is turned. Always open purge valves slowly. These valves contain no packing, so some fluid will occur when the valves are opened. operating personnel must protect themselves from exposure to system fluids.

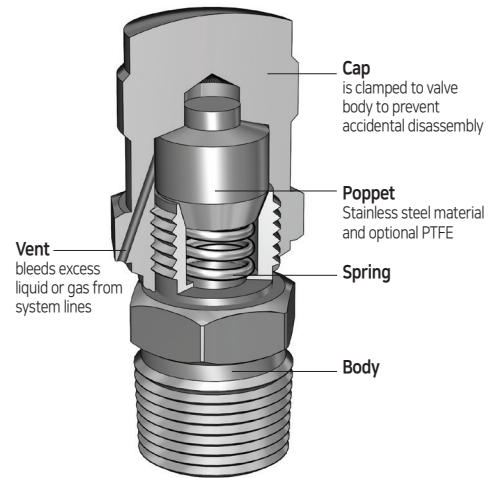

## Materials of Construction

Component	Valve Body Materials
Cap	316 SS / A276
Body	316 SS / A276
Poppet	316 SS / A276
Spring	304 SS

## Technical Data

Series	Pressure - Temperature Rating	
	Temperature	Working Pressure
SPUV	-65 to 600°F (-54 to 315°C)	4,000psig (275bar) @100°F (38°C)

## Pressure - temperature ratings

Temperature, °F(°C)	Working Pressure, psig (bar)
-65(-53) to 100(37)	4,000(275)
150(65)	3,720(256)
200(93)	3,440(237)
300(148)	3,105(213)
350(176)	2,975(204)
400(204)	2,850(196)
450(232)	2,750(189)
500(260)	2,650(182)
600(315)	2,500(172)

• Rating based on 316 stainless steel body material.

## Table of Dimension

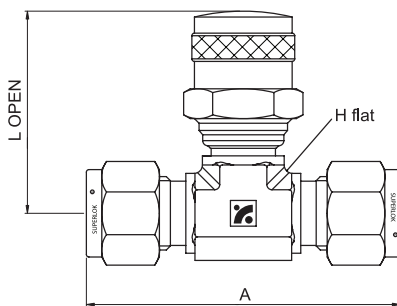

Union Type

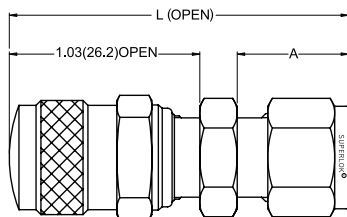

Straight Type

## Union Type

Part Number	Inlet End Connection	Dimensions in.(mm)			
		L	A	H	
SPUV	S4-UT	1/4" SUPERLOK	1.49(38.0)	2.26(57.5)	0.63(15.9)
	S6-UT	3/8" SUPERLOK	1.49(38.0)	2.40(61.0)	0.63(15.9)
	S8-UT	1/2" SUPERLOK	1.61(41.0)	2.82(71.6)	0.81(20.6)

## Straight Type

*Part Number	Inlet End Connection	Dimensions in.(mm)		
		L	H	
F2N	1/8" Female NPT	1.56 (39.6)	0.53 (13.5)	
F4N	1/4" Female NPT	1.75 (44.4)	0.72 (18.3)	
F6N	3/8" Female NPT	1.81 (46.0)	0.78 (19.8)	
F8N	1/2" Female NPT	1.98 (50.3)	0.97 (24.6)	
M2N	1/8" Male NPT	1.62 (41.1)	0.38 (9.7)	
M4N	1/4" Male NPT	1.81 (46.0)	0.56 (14.2)	
M6N	3/8" Male NPT	1.84 (46.7)	0.56 (14.2)	
M8N	1/2" Male NPT	2.09 (53.1)	0.75 (19.1)	
SPUV	S2	1/8" SUPERLOK	1.84 (46.7)	0.59 (15.0)
	S4	1/4" SUPERLOK	1.94 (49.3)	0.69 (17.5)
	S6	3/8" SUPERLOK	2.03 (51.6)	0.75 (19.1)
	S8	1/2" SUPERLOK	2.19 (55.6)	0.88 (22.4)
	S6M	6mm SUPERLOK	1.94 (49.3)	0.69 (17.5)
	S8M	8mm SUPERLOK	2.00 (50.8)	0.72 (18.3)

- Components can limit the pressure and temperature ranges of the valve. Please consult BMT (SUPERLOK) sales representative for your specific application.
- Dimensions and Drawings are for reference only and are subject to change without prior notice.
- Unless otherwise specified, all dimensions are in millimeters.
- Sizes, pressure classes, and end connections not listed are available upon request.
- Dimensions shown with SUPERLOK nuts finger-tight, where applicable.

## Table of Dimension

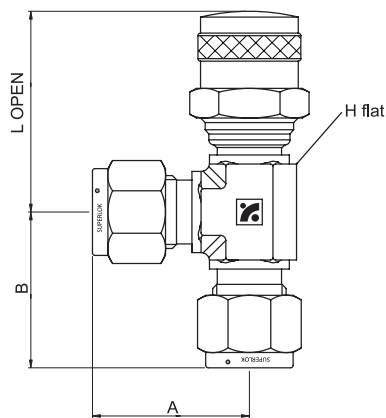

Elbow Type

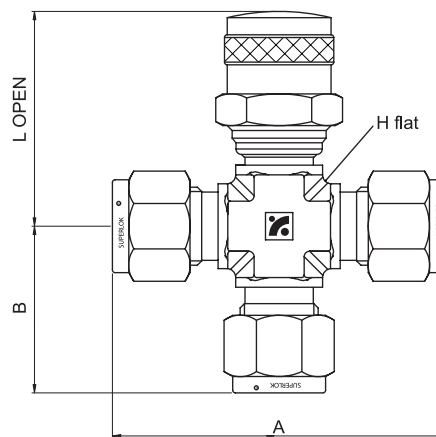

Tee Type

Part Number	Inlet End Connection	Dimensions, in.(mm)			
		L	A	B	H
SPUV	S4-ET	1.49 (38.0)	1.13 (28.8)	1.13 (28.8)	0.63 (15.9)
	S6-ET	1.49 (38.0)	1.20 (30.5)	1.20 (30.5)	0.63 (15.9)
	S8-ET	1.61 (41.0)	1.41 (35.8)	1.41 (35.8)	0.81 (20.6)

Part Number	Inlet End Connection	Dimensions, in.(mm)			
		L	A	B	H
SPUV	S4-TT	1.49 (38.0)	2.26 (57.5)	1.13 (28.8)	0.63 (15.9)
	S6-TT	1.49 (38.0)	2.40 (61.0)	1.20 (30.5)	0.63 (15.9)
	S8-TT	1.61 (41.0)	2.82 (71.6)	1.41 (35.8)	0.81 (20.6)

- Dimensions and Drawings are for reference only and are subject to change without prior notice.
- Unless otherwise specified, all dimensions are in millimeters.
- Sizes, pressure classes, and end connections not listed are available upon request.
- Dimensions shown with SUPERLOK nuts finger-tight, where applicable.

## Ordering Information

Example : **SPUV - S 4 - UT - B**

1
2
3
4
5

### 1. Valve Series

- SPUV

### 2. End Connection

- S = SUPERLOK Tube Fitting
- F = Female Thread
- M = Male Thread

### 3. End Connection Size

#### Tube O.D Designator

Tube O.D (inch)	1/4	3/8	1/2
Designator	4	6	8
Tube O.D (mm)	6	10	12
Designator	6M	10M	12M

#### Pipe Thread Designator

Size (inch)	1/8	1/4	3/8	1/2
BSPT	2R	4R	6R	8R
NPT	2N	4N	6N	8N

### 4. Pattern Designator

- (Blank) = Straight Type
- UT = Union Type
- ET = Elbow Type
- TT = Tee Type

### 5. Body Material

- (Blank) = 316 Stainless Steel
- B = Brass

**Memo**



# BMT Co., Ltd.

## Headquarters

(46031) 부산시 기장군 장안읍 신소재산단2로 17 (반룡리)

17, Sinsojaesandan 2-ro, Jangan-eup, Gijang-gun, Busan, 46031 South Korea

TEL: +82 51 780 5000 FAX: +82 51 780 5100

E-mail: [superlok@superlok.com](mailto:superlok@superlok.com)

WEB: [www.superlok.com](http://www.superlok.com)

## Fittings & Valves

### Industrial

Instrumentation Tube Fittings

i-Fitting®

Ball/Plug Valves

Double Block & Bleed Valves

Manifold/Gauge Valves

Globe/Needle Valves

Cryogenic Valves

Check/Relief/Excess Flow Valves

Medium/High Pressure Fittings & Valves

Eco-fuel Conversion and Supply Units

### Ultra High Purity

HGS® (High-integrated Gas System)

Weld & Metal Face Seal Fittings

Bend Fittings

Diaphragm Valves

Bellows Valves

Check Valves

Clean Ball Valves

Regulators

Gas Filters

HGS® : Trademark registered in Republic of Korea (as of April 2024)

## Electric & Energy

Metal Clad Switchgear (MCSG)

Compact Switchboard

Motor Control Center (MCC)

Smart Distribution Board

Energy Management System (EMS)